

**UNIVERSITY COLLEGE TATI (UC TATI)****FINAL EXAMINATION QUESTION BOOKLET**

COURSE CODE	: BME 3093
COURSE	: INDUSTRIAL ENGINEERING
SEMESTER/SESSION	: 2-2023/2024
DURATION	: 3 HOURS

Instructions:

1. This booklet contains 4 questions. Answer **ALL** questions.
2. All answers should be written in answer booklet.
3. Write legibly and draw sketches wherever required.
4. If in doubt, raise your hands and ask the invigilator.

DO NOT OPEN THIS BOOKLET UNTIL YOU ARE TOLD TO DO SO
THIS BOOKLET CONTAINS 5 PRINTED PAGES INCLUDING COVER PAGE

QUESTION 1

- a) Why is it important to assess manufacturability in process engineering? **Discuss** the factors considered during the assessment. (6 Marks)
- b) **Clarify** the considerations in selection of an equipment or process. (4 Marks)
- c) **Prepare** a product structure tree and list the level for an item X. X is composed of two Bs and one C. Moreover, each B requires three Ds and one E., and each D requires four Es. Similarly, each C is made up of two Es and two Fs. (10 Marks)
- d) **Sketch** a flow process chart for activities below. (10 Marks)
- | | | |
|--|---------|--------|
| FLOW PROCESS CHART | ANALYST | PAGE |
| Job: Machine Part with Cutting Machine | N.Jill | 1 of 1 |

Details of method

Check oil level

To oil barrel location

Fill the mist oil into machine

To the raw material storage rack

Identify the raw material location of required grade

To the crane location

Move the crane to the desired location

Adjust the crane rope to hold the bundle, Insert

Move the raw material to cutting machine using

Remove the wire to separate the bars from bundle

QUESTION 2

- a) A manager wants to assign tasks to workstations as efficiently as possible and achieve an hourly output of four units. The department uses a working time of 56 minutes per hour. **Apply** the tasks shown in the accompanying precedence diagram (times are in minutes) to workstations using the following rules:
- In order of most following tasks. Tiebreaker: greatest positional weight. (9 Marks)
 - In order of greatest positional weight. Tiebreaker: most following tasks. (9 Marks)
 - Determine** the efficiency of the system. (2 Marks)

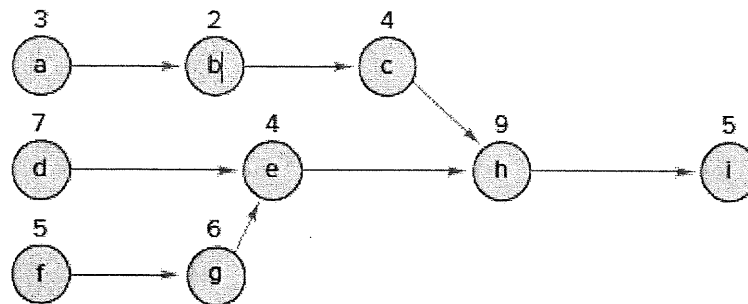

INDUSTRIAL ENGINEERING (BME 3093)

QUESTION 3

- a) **Discuss** the principles of motion study. (3 Marks)
- b) **Contrast** the meanings of the terms *job enlargement* and *job enrichment*. (4 Marks)
- c) The elemental times (in minutes) for 4 cycles of an operation using a stop watch are presented below:

Cycle Times in Minutes

Element	1	2	3	4
1	1.5	1.5	1.3	1.4
2	2.6	2.7	2.4	2.6
3	3.3	3.2	3.4	3.4
4	1.2	1.2	1.1	1.2
5	0.51	0.51	0.52	0.49

Calculate standard time for the operation if:

- (i) Elements 2 and 4 are machine elements
- (ii) For other elements, the operator is rated at 110%
- (iii) Total allowances are 15% of the job time. (13 Marks)

QUESTION 4

- a) List two examples of MSD and **explain** the common cause of it. (6 Marks)
- b) **Discover** the areas of application of ergonomics. (4 Marks)
- c) **Interpret** the term ergonomic risk factors and its consideration in workplace. (12 Marks)
- d) **Determine** the ergonomic program for effective control of occupational ergonomic hazards. (8 Marks)

-----End of question-----

